

PHYS 235: Homework Problems

1. The illustration is a facsimile of an oscilloscope screen like the ones you use in lab. A sinusoidal signal from your function generator is the input for Channel 1, and your scope is set so that the horizontal axis in the middle of the screen is ground (0 V).

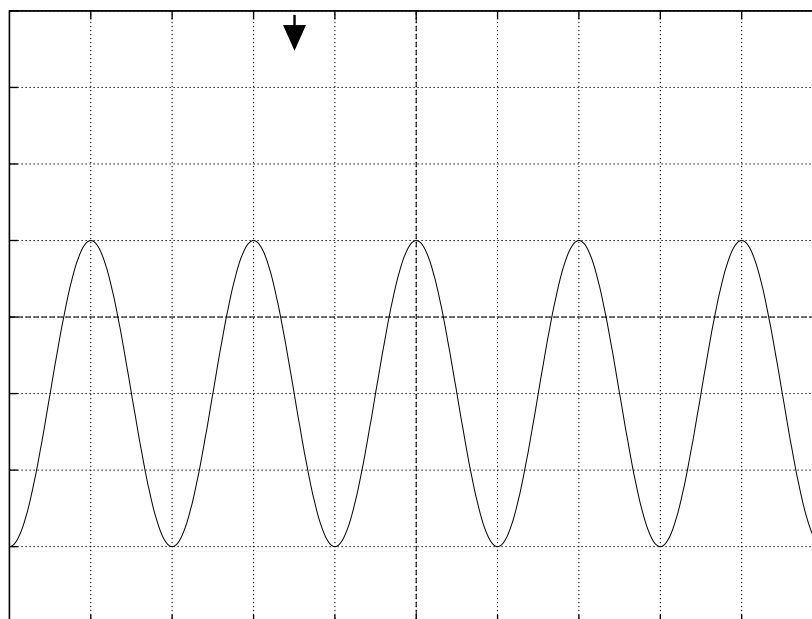

CH1 20.0 mV

500 μ s

- (a) What is the Trigger Slope setting: Rising or Falling?
- (b) What is the Trigger Level setting? (This is the voltage value that would be displayed in the lower righthand corner of the screen.)
- (c) Is the CH 1 Coupling set to DC or AC?
- (d) Using the trigger point as time $t = 0$, determine the function describing the input signal, i.e., determine the constants a , b , c , and d in the expression

$$v(t) = a \sin(bt + c) + d.$$

2. Calculate the resistance between terminals A and B.

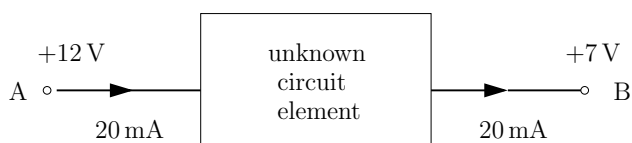

3. Your function generator is set to produce a sinusoidal voltage with an amplitude of 0.2 V , a frequency of 100 kHz , and zero offset. The trigger on your scope is set to **Slope: Rising**, and the trigger level -0.1 V . Sketch the waveform that appears on your oscilloscope. You must indicate horizontal and vertical scale settings on your diagram, and these must correspond to real scale settings on your oscilloscopes. Note that the trigger point is indicated in the illustration, and assume that your scope is set so that the horizontal axis in the middle of the screen is ground (0 V).

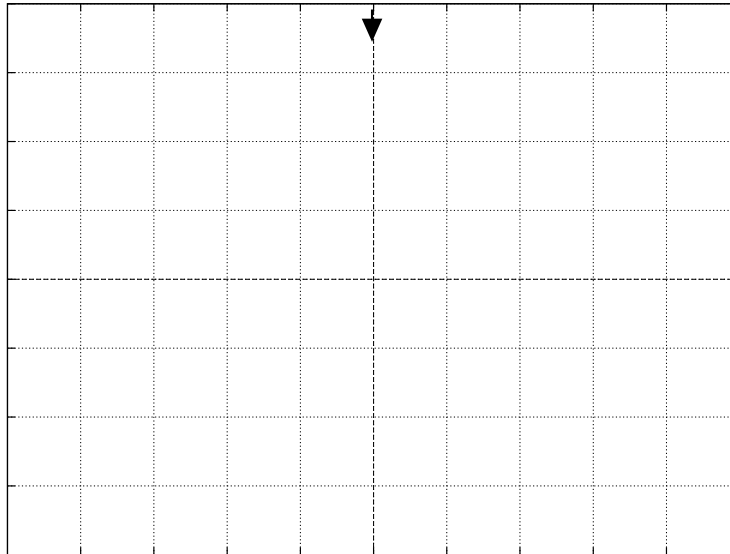

4. (a) Define current.
(b) Define electric potential or voltage. What are the MKS units of voltage? What does “ground” mean?
5. Consider a copper wire that is 0.25 m long, with a diameter of 0.5 mm . The wire carries a current of 10 mA .
- (a) Calculate the resistance of the wire.
(b) How many electrons per second flow past a fixed point in the wire?
(c) What is the voltage drop between the ends of the wire when the 10 mA current is flowing. Is this consistent with the standard approximation that wires are essentially equipotentials?
(d) What is the drift velocity of the electrons in the wire?

6. Calculate the voltage at points A, B, C, D, and E (relative to ground) if

- (a) point D is grounded,
- (b) point E is grounded,
- (c) point A is grounded, and
- (d) point B is grounded.

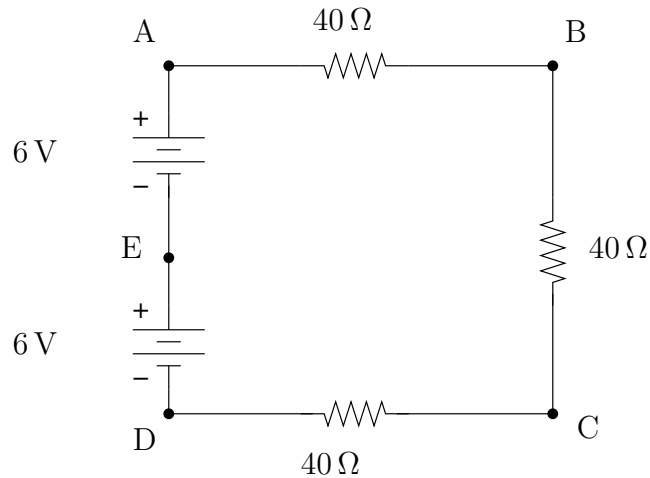

7. The power supply on your benchtop has three outputs, labeled +, -, and GND. How should you connect these to get -5 V (with respect to ground) to a point on your proto-board?

8. Calculate the voltage at points A, B, and C in the illustrated circuit.

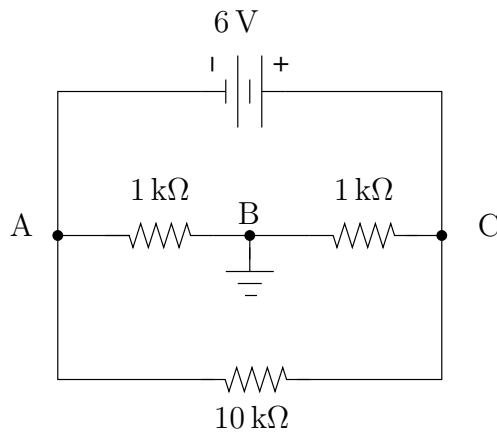

9. A fixed $1\text{ k}\Omega$ resistor is connected in series to a $4\text{ k}\Omega$ potentiometer (i.e., variable resistor). The series combination is connected to an ideal 5.0 V battery. Calculate the minimum and the maximum values of V_{AB} as the shaft of the potentiometer is rotated.

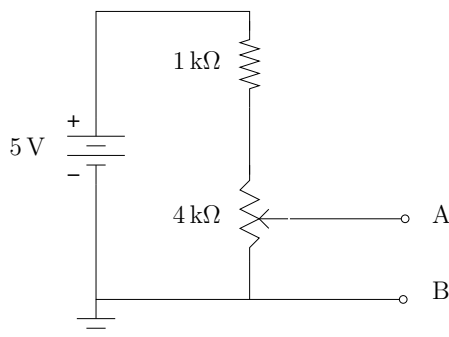

10. Calculate the voltage between points A and B. Which point is at a higher potential, A or B?

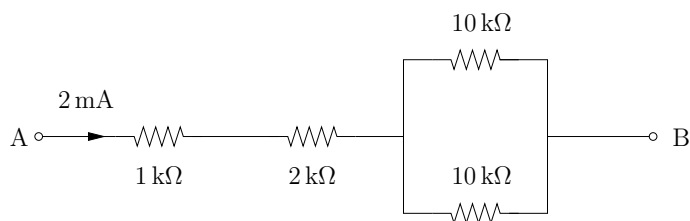

11. Calculate the current I .

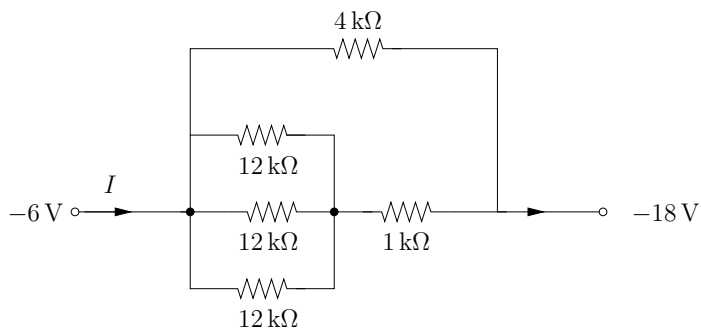

12. The illustrated circuits are built from a set of identical resistors and identical (new) batteries.

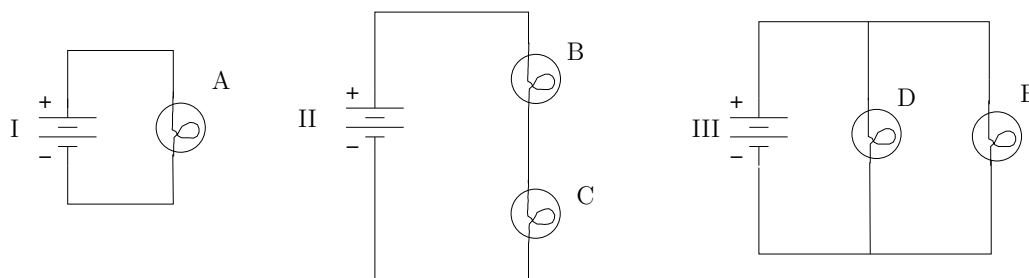

- (a) Rank the five bulbs in order of brightness.
- (b) Rank the batteries in order of how long they will last, from longest duration to shortest duration.
13. Calculate I_1 and I_2 in the illustrated circuit.

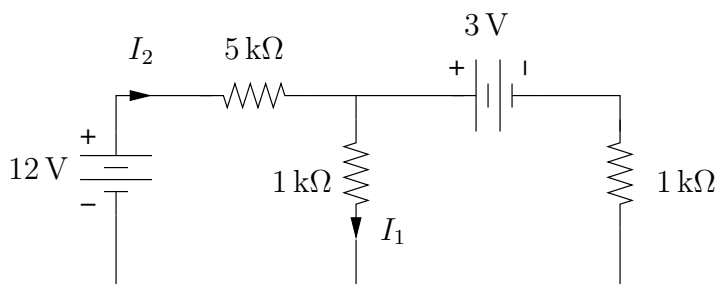

14. Calculate I_1 , I_2 , and I_3 in the illustrated circuit.

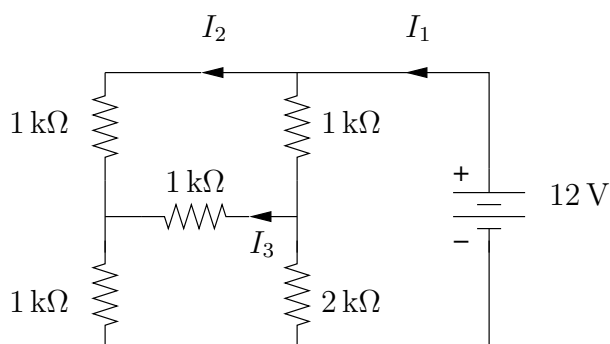

15. Describe an ideal voltage source and an ideal current source.

16. Assume that the voltmeter in the illustrated circuit is an oscilloscope with a $1\text{ M}\Omega$ input impedance. (The input resistance of the scope is not shown in the figure.) Calculate the voltmeter reading for

- (a) $R = 1\text{ k}\Omega$, and
(b) $R = 1\text{ M}\Omega$.

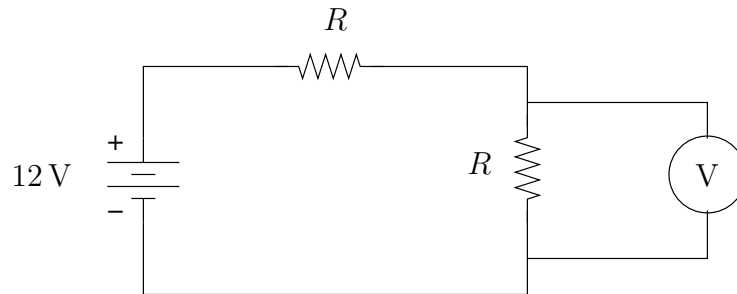

17. A 1 W , $1\text{ k}\Omega$ carbon resistor carries a current of 30 mA . Calculate the power dissipated as heat in the resistor. Would this situation be desirable in a circuit?
18. An automobile battery has a terminal voltage of 12.8 V with no load. When the starter motor is being turned over it loads the battery, drawing 90 A of current, and the terminal voltage of the battery drops to 11 V . Calculate the internal resistance of the battery.
19. A 30 V DC power supply has an internal resistance of 2Ω . Calculate the terminal voltage when the power supply is hooked up to a load resistor that draws a current of 500 mA from the supply.
20. Standard batteries are not ideal voltage sources; they can be modeled as an ideal voltage source V_S in series with an internal resistance R_{int} . When a battery goes bad, it's *not* because the value of V_S goes down, it's because R_{int} goes up. One consequence of this is that you can't use a standard voltmeter (like the ones you use in lab) to check if a battery is good. Explain why this is so, and describe qualitatively the characteristics of a meter that could check batteries.

21. How large should the heater resistance R_H be to draw the most power from a 12 V battery with an internal resistance of $3\ \Omega$? Calculate the power dissipated in the heater and in the battery under such conditions.

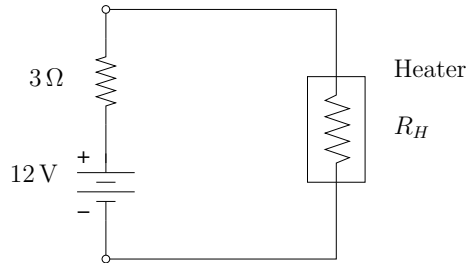

22. Calculate the Thévenin equivalent circuit.

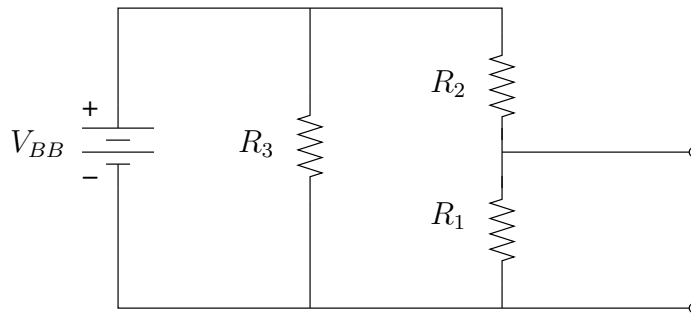

23. Calculate the Thévenin equivalent circuit.

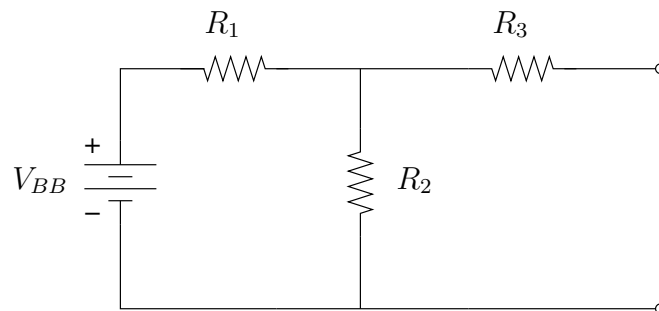

24. Calculate the Norton equivalent for the illustrated circuit at the indicated output terminals.

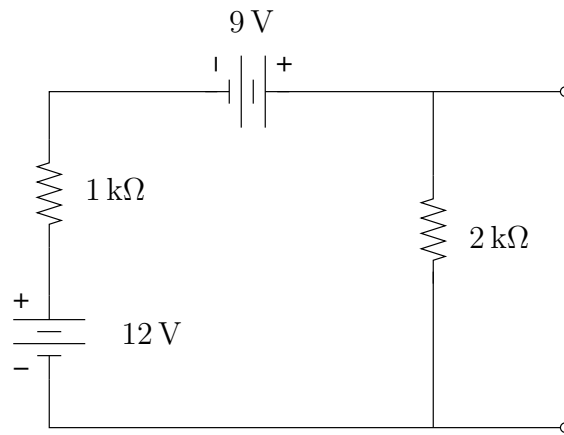

25. Consider the illustrated DC circuit. (All transients have died out, and the currents and charges have reached their equilibrium values.) Calculate the charge on the capacitor.

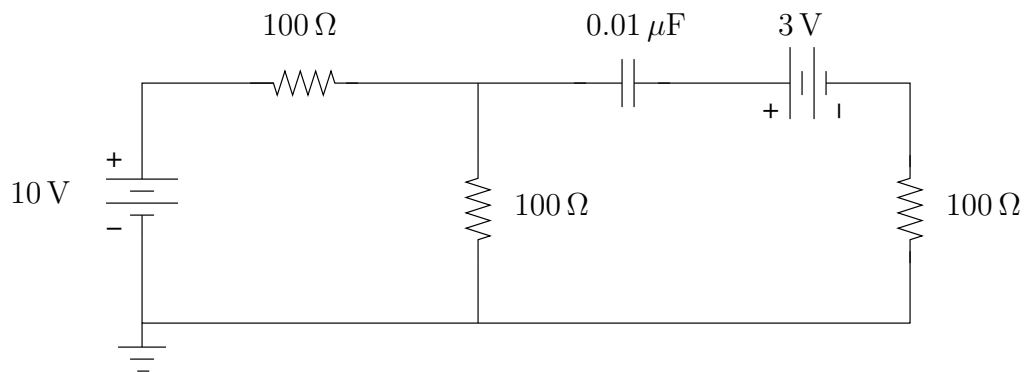

26. Consider the illustrated circuit that starts with the capacitor initially uncharged. The switch S is closed, and the capacitor begins to charge. What is the time interval between the time the capacitor is charged to 3V and the time the capacitor is charged to 3.78V?

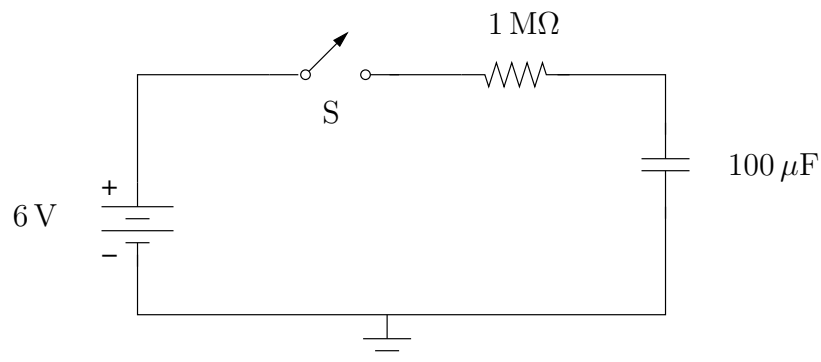

27. Prove that the 10% to 90% rise time for a RC low-pass filter is $2.2RC$ for a perfect step-function input.
28. Sketch the approximate output from an RC integrating circuit with $R = 10\text{ k}\Omega$ and $C = 0.01\text{ }\mu\text{F}$ for the illustrated inputs. For the input on the left, make sure that your sketch of the output has an appropriate time scale indicated on the axis.

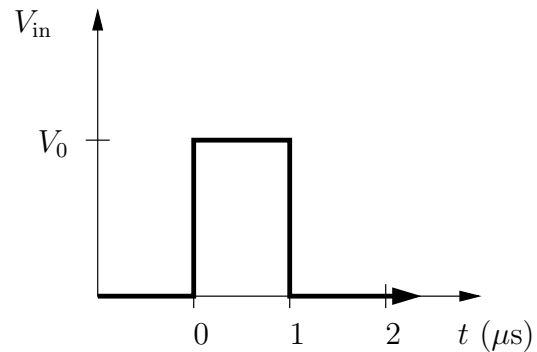
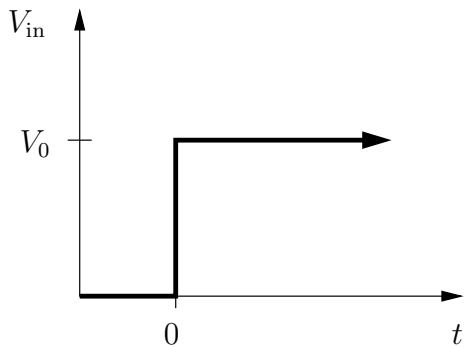

29. Sketch the approximate output from an RC differentiating circuit with $R = 10\text{ k}\Omega$ and $C = 0.4\text{ nF}$ for the illustrated inputs. For the input on the left, make sure that your sketch of the output has an appropriate time scale indicated on the axis.

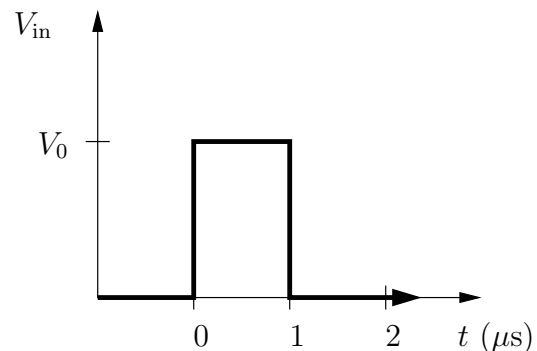
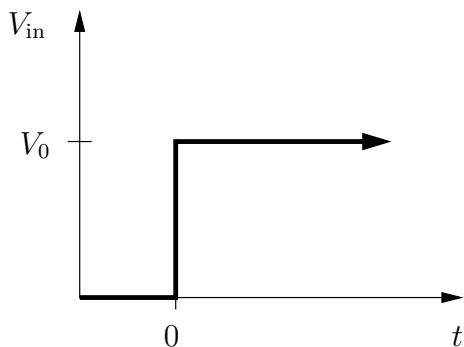

30. Calculate the capacitive reactance (i.e., magnitude of the impedance) in ohms of a $0.01\text{ }\mu\text{F}$ capacitor at (a) 100 Hz , (b) 1 kHz , (c) 100 kHz , (d) 1 MHz .

31. Calculate the impedance Z_{AB} in the forms $a + jb$ and $|z|e^{j\theta}$ for the two RC combinations illustrated.

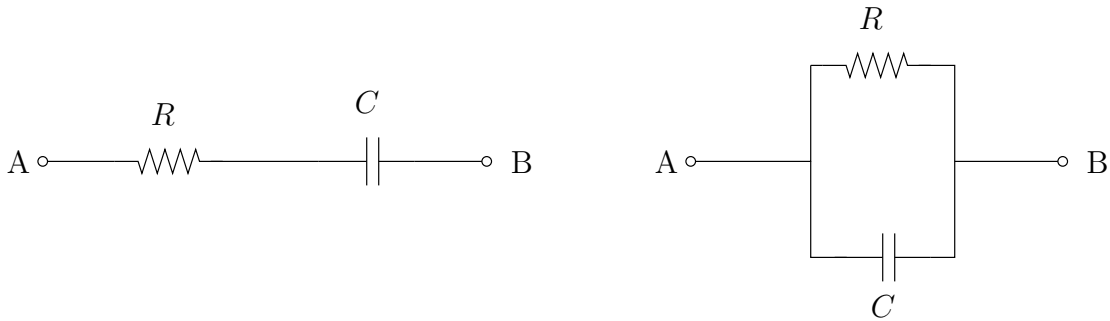

32. Design a high-pass filter with a breakpoint at 100 kHz.
33. Design a low-pass filter that will attenuate a 60 Hz signal by 12 dB relative to the DC gain. Use a $100\ \Omega$ resistance.
34. For a low-pass RC filter prove that at the frequency $\omega = 2/RC$ the voltage gain equals $1/\sqrt{5} = 0.447$.
35. Draw the phasor voltage diagram for a high-pass filter for a frequency $\omega = 1/(RC)$. Make sure all phasors have the correct relative lengths and angles. Use your diagram to calculate the phase shift of the output voltage relative to the input voltage.
36. Draw the phasor voltage diagram for a high-pass filter for a frequency $\omega = 1/(2RC)$. Make sure all phasors have the correct relative lengths and angles. Use your diagram to calculate the phase shift of the output voltage relative to the input voltage.

37. The illustrated voltage vs. time graph is a combination of a signal and unwanted 1000 Hz noise. Design a filter that will significantly attenuate the 1000 Hz noise, but leave the signal unattenuated.

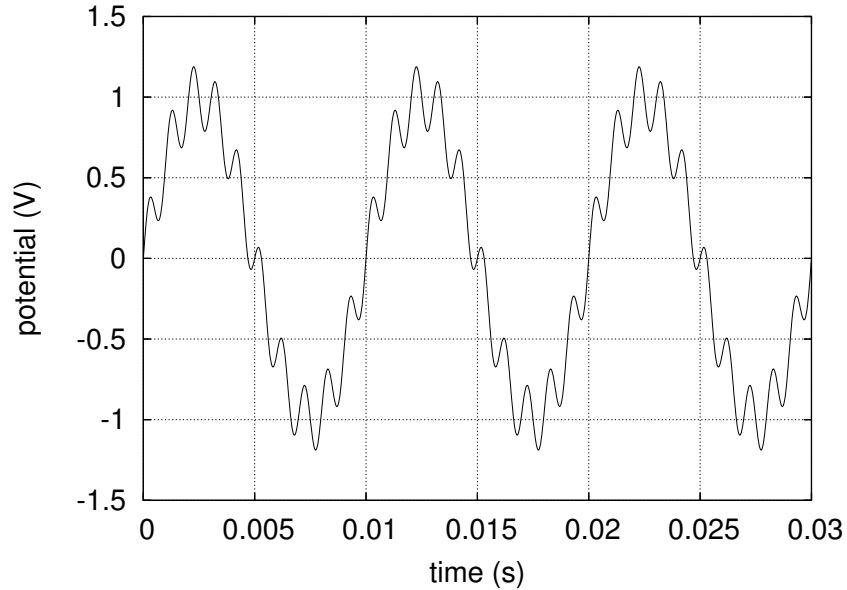

38. The illustrated voltage vs. time graph is a combination of a signal and unwanted 1000 Hz noise. Design a filter that will significantly attenuate the 1000 Hz noise, but leave the signal unattenuated.

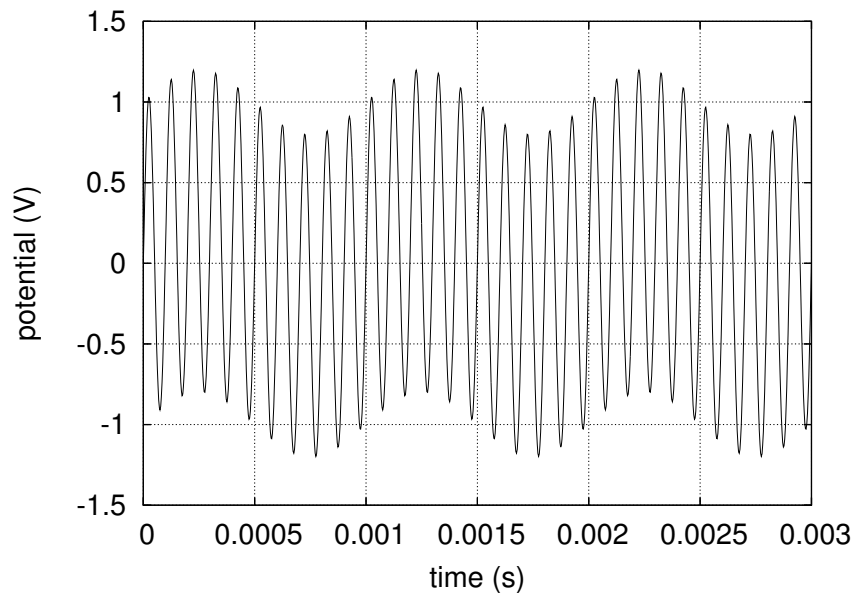

39. Calculate the inductive reactance (i.e., magnitude of the impedance) in ohms of a 2.5 mH coil at (a) 100 Hz, (b) 1 kHz, (c) 100 kHz, (d) 1 MHz.

40. Calculate the impedance Z_{AB} in the forms $a+jb$ and $|z|e^{j\theta}$ for the two RL combinations illustrated.

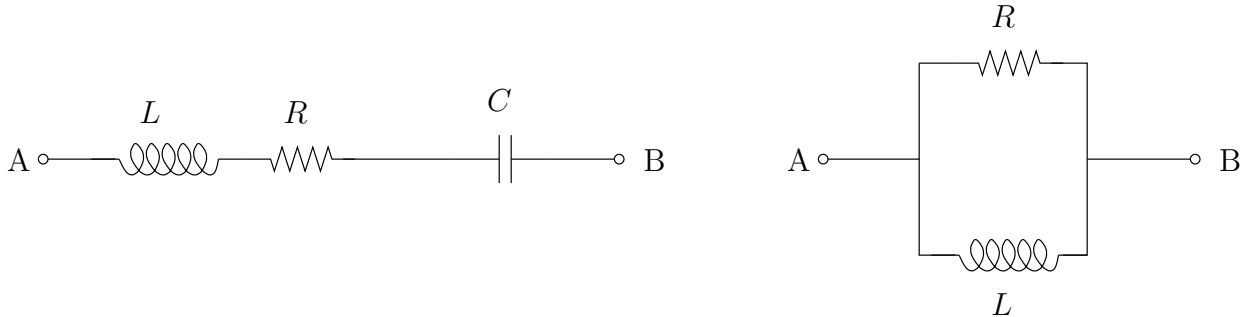

41. Calculate the impedance Z_{AB} in the form $a + jb$ for the illustrated RLC combination.

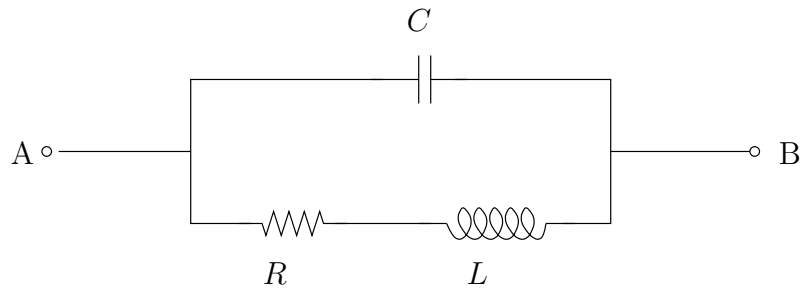

42. Sketch the phasor voltage diagram for a series RLC circuit at resonance.
43. Derive an expression for the voltage gain and the phase shift for the illustrated LR filter. Make a sketch of the gain vs. angular frequency.

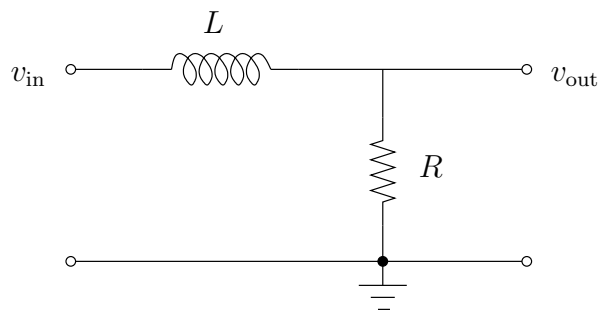

44. Calculate the approximate current in the illustrated circuits containing a silicon diodes.

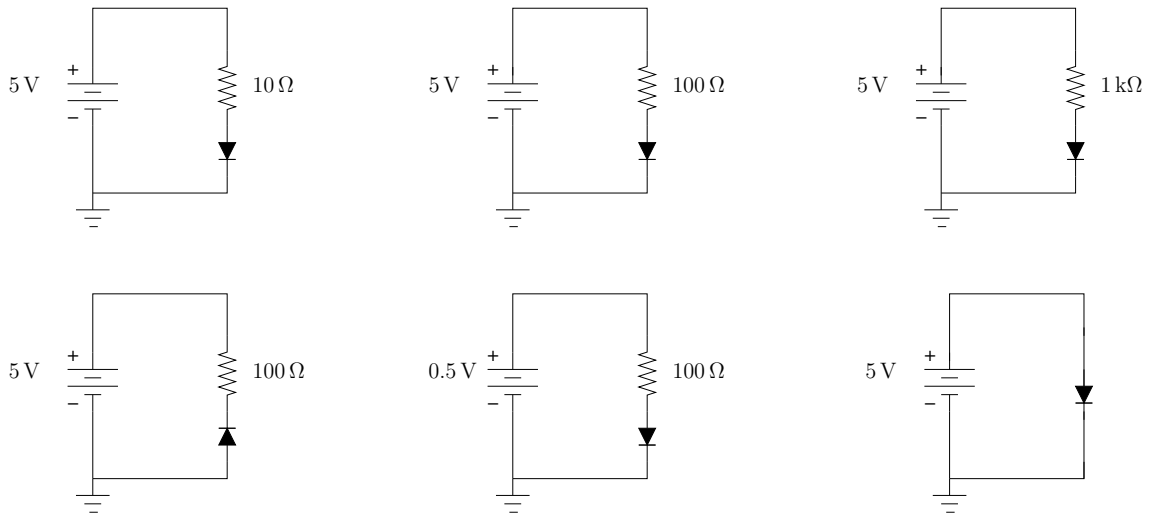

45. Repeat the previous problem for LEDs with a turn-on voltage of 2.5 V.

46. You want to design a circuit so that an LED with a turn-on voltage of 2.0 V and powered from a 5 V supply will run with a current of 15 mA. (The appropriate range of current for an LED is usually given in the specifications for a device when you buy it.) Choose an appropriate load-limiting resistor, and draw your circuit.

47. Design a diode clipping circuit to clip negative-going pulses so that the output is never more negative than -3 V.

48. Consider the illustrated circuit containing a silicon diode and a resistor.

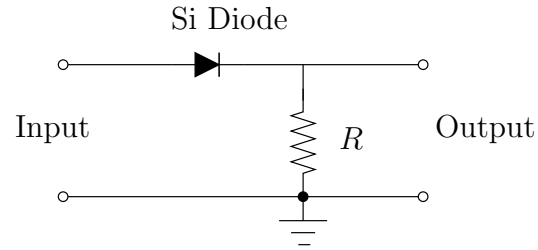

Sketch the voltage output waveform for each of the illustrated inputs.

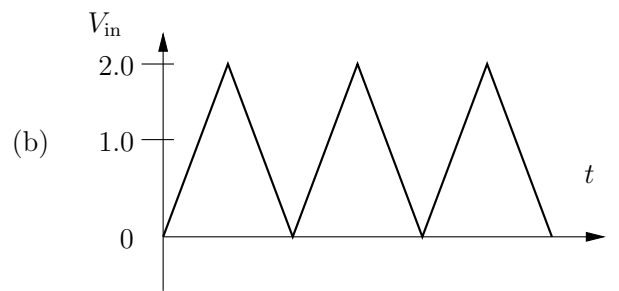
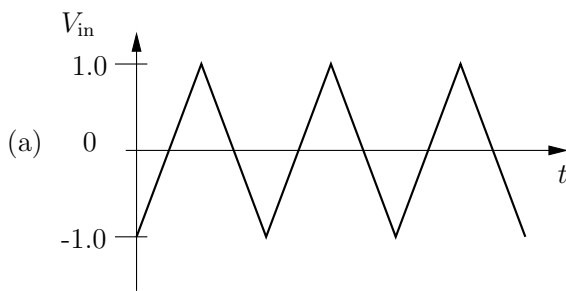

49. Consider the illustrated circuit containing a silicon diode and a resistor.

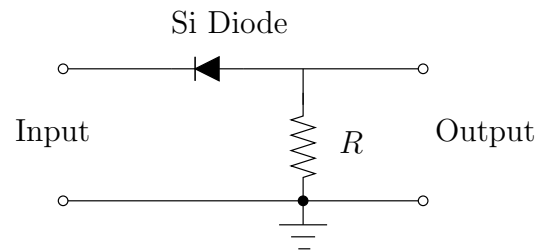

Sketch the voltage output waveform for the illustrated input.

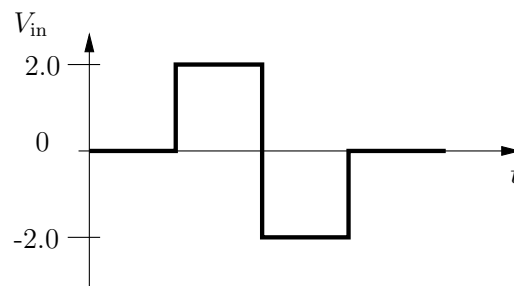

50. Consider the illustrated circuit containing a battery, a silicon diode and a resistor.

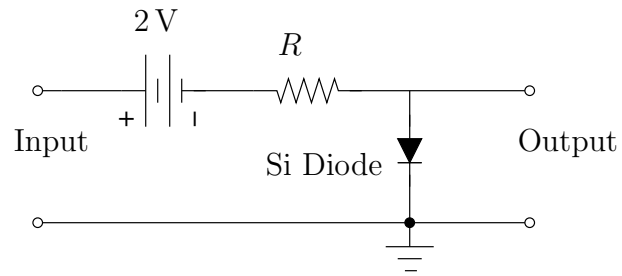

Sketch the voltage output waveform for the illustrated input.

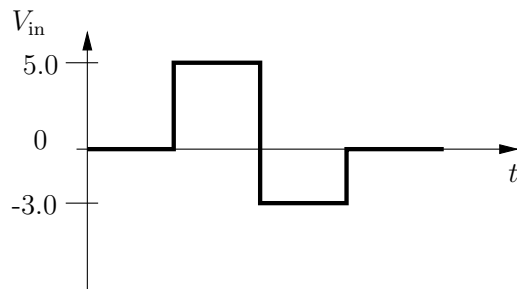

51. Explain why the ripple amplitude in the output of an unregulated power supply increases as the load resistance is decreased.