

BUCKNELL UNIVERSITY
Computer Science
CSCI 315 Operating Systems Design

Processes

Notice: The slides for this lecture have been largely based on those accompanying an earlier version of the textbook *Operating Systems Concepts with Java*, by Silberschatz, Galvin, and Gagne. Many, if not all, the illustrations contained in this presentation come from this source.

Chapter 3

Processes

1/27/2010

CSCI 315 Operating Systems Design

2

Process Concept

- Process – a program in execution; process execution must progress in sequential fashion.
- A process includes:
 - program counter,
 - stack,
 - data section.

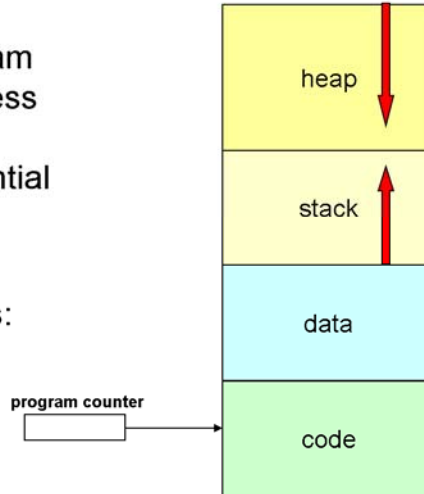

1/27/2010

CSCI 315 Operating Systems Design

3

Process State

As a process executes, it changes **state**:

- **new**: The process is being created.
- **running**: Instructions are being executed.
- **waiting**: The process is waiting for some event to occur.
- **ready**: The process is waiting to be assigned to a processor.
- **terminated**: The process has finished execution.

Process State Transition Diagram

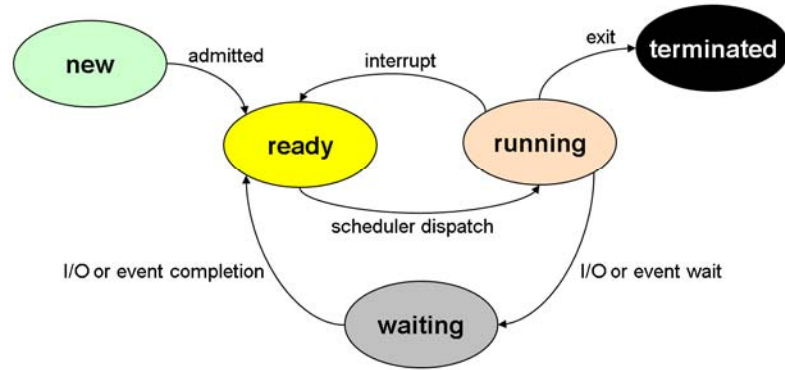

1/27/2010

CSCI 315 Operating Systems Design

5

Process Control Block (PCB)

OS bookkeeping information
associated with each process:

- Process state,
- Program counter,
- CPU registers,
- CPU scheduling information,
- Memory-management information,
- Accounting information,
- I/O status information,
-

process id
process state
program counter
registers
memory limits
list of open files
⋮

CPU Switching

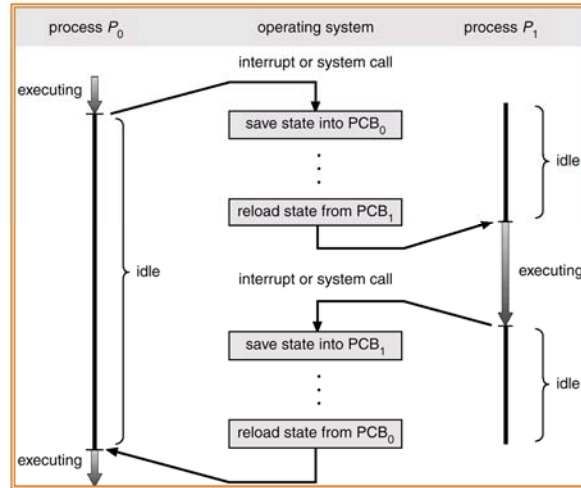

Process Scheduling Queues

- **Job queue** – set of all processes in the system.
- **Ready queue** – set of all processes residing in main memory, ready and waiting to execute.
- **Device queues** – set of processes waiting for an I/O device.

Processes migrate between the various queues.

Processes and OS Queues

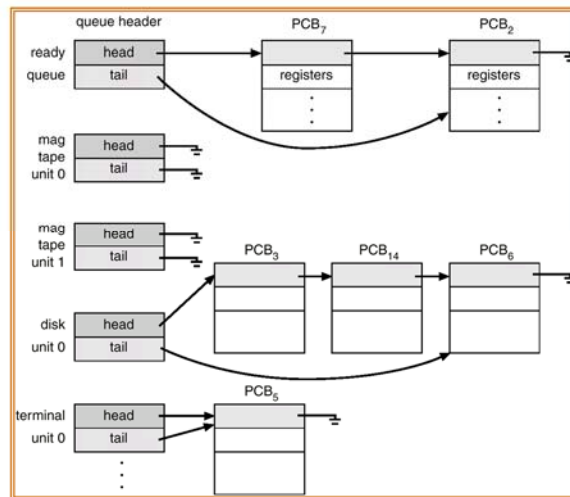

1/27/2010

CSCI 315 Operating Systems Design

9

Process Scheduling

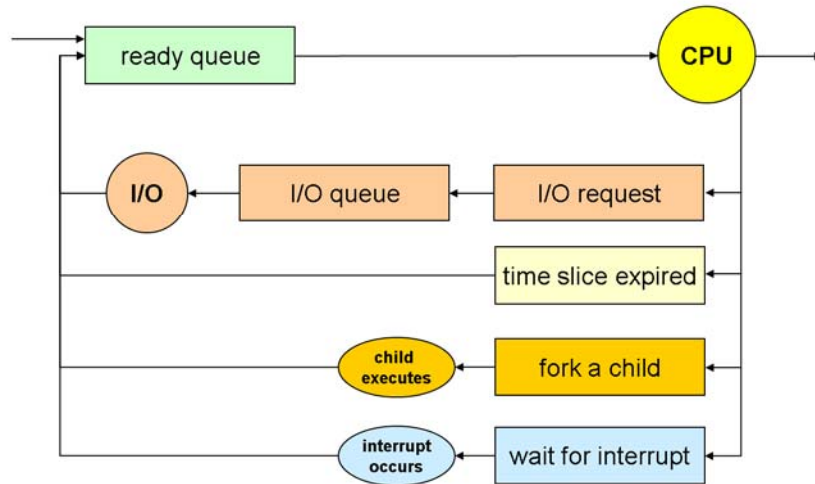

1/27/2010

CSCI 315 Operating Systems Design

10