

Homework Assignment #10 – do not submit

Ungraded Problems:

The following problems will not be graded, but you should attempt to solve them on your own and then check the solutions. Do not give up too quickly if you struggle with one or more of them. Move on to a different problem and then come back to the difficult one after a few hours.

- The silicon npn BJT in the diagram to the right does not operate in the cut-off region. Suppose that the value of β ranges from 100 to 300 depending on temperature and manufacturing variability. Find the range of β values for which the BJT operates in the active region and the range for which it operates in the saturation region. Assume that the turn-on voltage V_F of the base-emitter junction is 0.7 V and that $V_{CE|sat} = 0.2$ V.

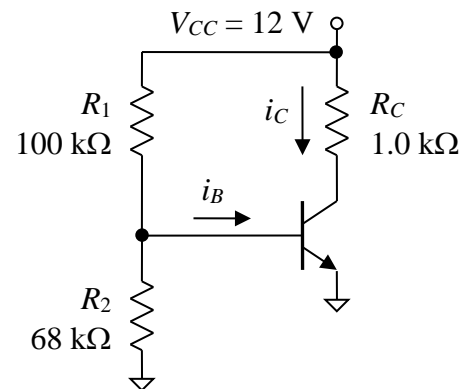

- For the circuit shown below, find the quiescent collector voltage V_C , the quiescent emitter voltage V_E , and the quiescent collector current I_C . Assume that $\beta = 150$, $V_{CE|sat} = 0.2$ V, and that the base-emitter (BE) junction can be modeled using a constant voltage drop of $V_F = 0.7$ V. Also find the region of operation of the BJT.

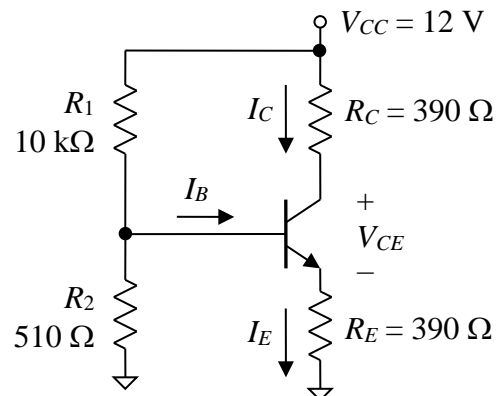

(continued on next page)

3. Repeat the previous problem for the case when R_2 has been changed to $6.8 \text{ k}\Omega$ and R_C has been changed to $1 \text{ k}\Omega$. All of the assumptions in the previous problem are valid for this one.

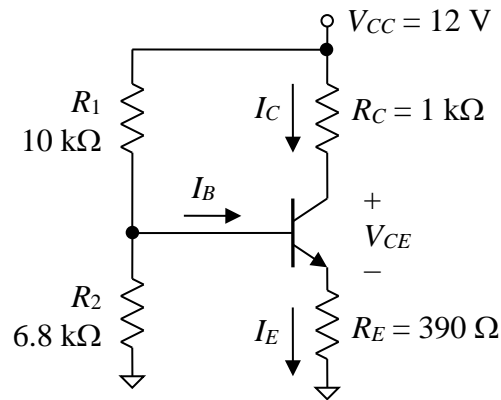

4. As shown below, an npn BJT is used to switch a white LED on or off depending on the output signal from a CMOS digital circuit. The CMOS circuit produces a logic 0 ($V_{sw} = 0 \text{ V}$; subscript “sw” for “switch”) at its output when the LED is to be off and a logic level 1 ($V_{sw} = 10 \text{ V}$) if the LED is to be on. The LED has a turn-on voltage of 3.2 V . The current-limiting resistor R_{lim} sets the LED current to an appropriate level when it is on. The LED’s operating current is more than the CMOS circuit can provide (the latter’s safety threshold is 2.0 mA); that is why the BJT is necessary. The BJT must operate in the cut-off region when $V_{sw} = 0 \text{ V}$, and it must operate in the saturation region when $V_{sw} = 10 \text{ V}$.

Find an appropriate value for resistor R_1 so that the circuit operates properly if the β value of the BJT ranges from 100 to 350. Assume that the turn-on voltage V_F of the base-emitter junction is 0.7 V and that $V_{CE|sat} = 0.2 \text{ V}$. As you select a value for R_1 , apply a $\times 2$ safety factor; that is, ensure that the base current will be at least two times the minimum required value to ensure proper operation. Also make sure that the base current is less than the maximum safe source/sink current of the CMOS circuit (2.0 mA). Note that the value of R_2 has already been set. Its value is not critical. It is called a “pull-down” resistor and is there to ensure that the BJT operates in the cut-off region even if the CMOS circuit has a failure that presents an open circuit to the base terminal of the BJT. It is good design practice to include a pull-down resistor in most switching circuits.

