

Homework Assignment #5 – due via Moodle at 11:59 pm on Friday, Oct. 6, 2023

Instructions, notes, and hints:

You may make reasonable assumptions and approximations in order to compensate for missing information, if any. Provide the details of all solutions, including important intermediate steps. You will not receive credit if you do not show your work.

Graded Problems:

- In the noninverting amplifier shown below, the applied input voltage waveform $v_{in}(t)$ is a square wave with a peak value of 500 mV, a minimum value of zero, and a frequency of 4.0 kHz. The waveform has a 50% duty cycle (i.e., the “on” time is exactly equal to the “off” time during each cycle). The first zero-to-500 mV transition of the input voltage occurs at time $t = 0$. A sketch of the waveform is shown below right. The op-amp has a slew rate of $0.25 \text{ V}/\mu\text{s}$, an output current limit of 25 mA, and output voltage limits of -8.8 V and $+8.8 \text{ V}$. Provide a rough sketch of the output voltage waveform $v_o(t)$ below a sketch of $v_{in}(t)$ for reference. Indicate the important time transitions and voltage levels. Note that some factors could affect the waveform, and others might be negligible or have no effect. You must determine which ones are significant. You may assume that the input bias currents and input bias voltage are zero and that a perfect virtual short exists if negative feedback is present.

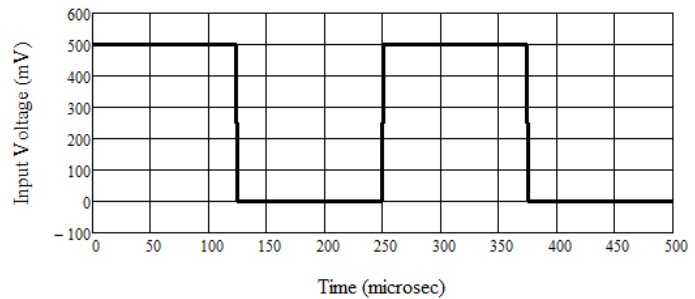
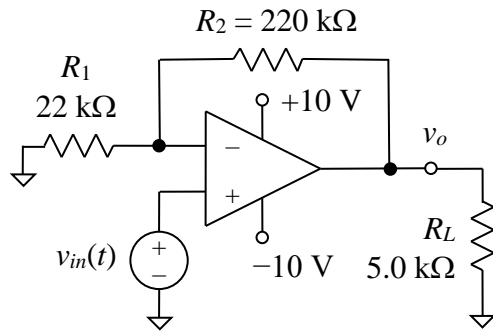

- Consider the op-amp circuit from the previous problem. Suppose that the frequency of the input signal is gradually increased but the peak-to-peak amplitude remains at 500 mV. Find the frequency at which the output voltage waveform becomes a triangle wave with a peak-to-peak amplitude of 500 mV.

(continued on next page)

3. Find the current i that flows through the circuit shown below. The two diodes are identical and have the parameter values $I_S = 1.0 \text{ nA}$, $\eta = 2.0$, and $V_T = 26 \text{ mV}$. This problem requires the solution of a transcendental equation. You may use your calculator to solve it if it has that capability; however, you should check that its solution is correct. Alternatively, you may use mathematical analysis software such as *Matlab*; if you do, include a copy of your session or script with your solution.

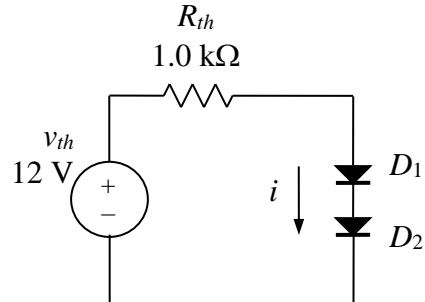

4. Find the voltage at the node marked v_O in the diagram below for the three indicated values of the voltage v_{IN} . The nodes labeled “+2.8 V” and “-2.8 V” are connected to the positive terminals of voltage sources that are not shown; the sources’ negative terminals are connected to ground. Thus, current can flow into and out of those nodes. Assume that the constant-voltage diode model with a turn-on voltage of $V_F = 0.7 \text{ V}$ applies and that any external circuitry connected to the terminal labeled v_O draws negligible current. Voltage v_O is a node voltage and is therefore referenced to the ground node. This is an example of a circuit that can protect the input port of a 3.3 V digital system from excessive voltage magnitudes coming from the signal source modeled by the TEC consisting of v_{IN} and R_1 .

- $v_{IN} = -6.0 \text{ V}$
- $v_{IN} = 2.0 \text{ V}$
- $v_{IN} = 5.0 \text{ V}$

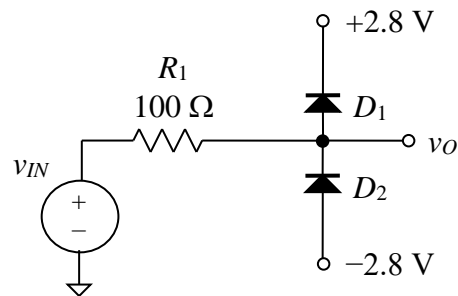

5. The circuit at the top of the next page depicts a standard full-wave bridge rectifier circuit. Assume that the constant-voltage diode model with a turn-on voltage of $V_F = 1 \text{ V}$ is valid for diodes D_1 through D_4 . Suppose that diode D_1 fails so that it acts like an open circuit. Sketch and label the resulting output voltage waveform $v_o(t)$ underneath a sketch of the secondary voltage waveform $v_{sec}(t)$ for reference. You should label all voltages in the v_{sec} and v_o waveforms at important transition points, but you do not have to label the times (relative or absolute) at which they occur. Be sure to include details such as brief periods (if any) when the output voltage is zero.

(continued on next page)

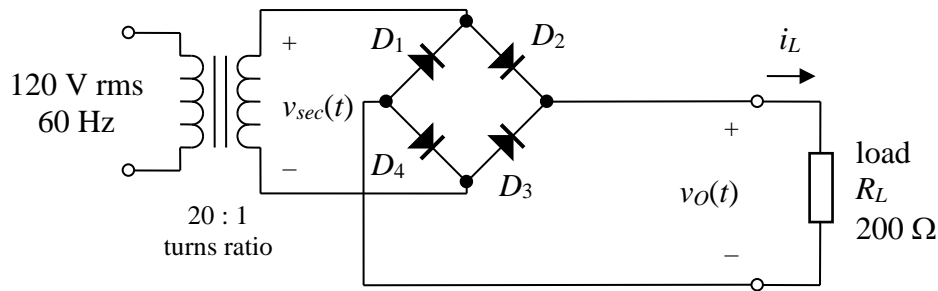

Circuit diagram for Graded Prob. 5

Ungraded Problems:

The following problems will not be graded. They are intended to serve as practice problems and examples. The solutions to these problems will be posted along with those to the graded ones. Do not give up too quickly if you struggle to solve any of them. Move on to a different problem and then come back to the difficult one after a few hours.

1. The input waveform applied to the noninverting amplifier shown below is a sinusoid with an amplitude of 400 mV (800 mVpp). The frequency is gradually increased from zero. Find the frequency at which the output voltage waveform begins to experience distortion (i.e., is no longer a perfect sinusoid). *Hint:* Neither output voltage limiting nor output current limiting is occurring.

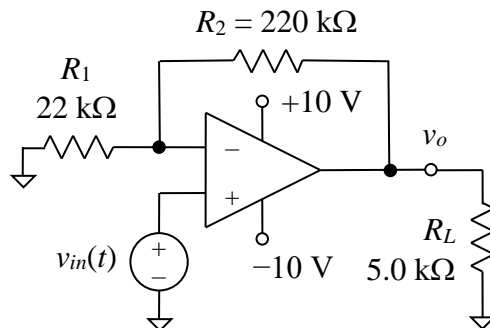

2. Show that the LED in the circuit below lights if the sum of the node voltages V_1 and V_2 exceeds 6 V (i.e., $V_1 + V_2 > 6$ V). Voltage sources not shown in the diagram are connected to the two terminals marked V_1 and V_2 , so current can flow into and out of those nodes. The specifications for the LED taken from the data sheet are shown below right. Assume that the constant-voltage model can be applied to the LED. The maximum safe current is exceeded if $V_1 + V_2 > 66$ V.

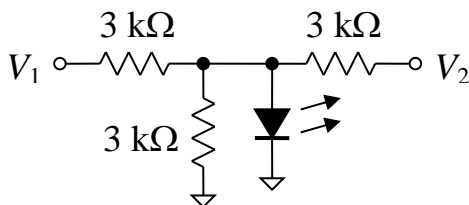

LED specifications:
 typ. forward voltage drop: $V_F = 2.0$ V
 max. power dissipation: $P_{\max} = 40$ mW
 max. forward current: $I_{F\max} = 20$ mA
 max. reverse voltage: $V_{R\max} = 10$ V

(continued on next page)

3. The standard diode equation is given by the expression below left, and an approximation of the equation for “large” values of v_D (the forward bias case) is given below right. Assuming that $n = 1$ and that the diode is at room temperature (20 °C), find the forward voltage v_D at which the “1” term in the parentheses in the diode equation can be ignored. The “1” is insignificant if ignoring it changes the calculated forward current i_D by less than 1%. Repeat the analysis for $n = 2$.

$$i_D = I_S \left(e^{v_D/nV_T} - 1 \right)$$

$$i_D \approx I_S e^{v_D/nV_T}$$

4. Find the labeled current I_1 and node voltage V in diagram (a) below. You may apply the constant-voltage diode model with $V_F = 0.7$ V. The nodes marked “+3 V” and “-3 V” are connected to voltage sources not shown, so current can flow into and out of those nodes. The node marked “V” is a test point, so it is not connected to anything except diode D_2 and the 6 k Ω resistor. Note that V is referenced to the ground node.

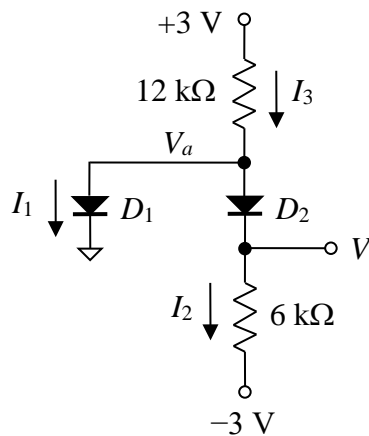

(a)

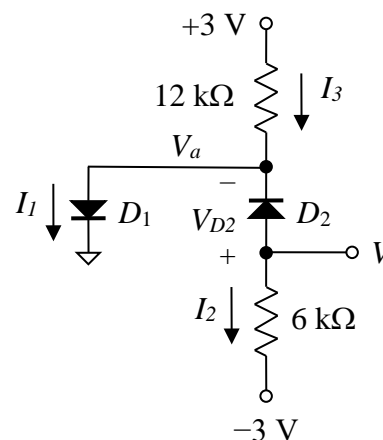

(b)

5. Find the labeled current I_1 and node voltage V in diagram (b) above. You may apply the constant-voltage diode model with $V_F = 0.7$ V. The explanatory notes given in the previous problem apply to this one as well.
6. Suppose that an air pressure monitor generates a voltage V_S that follows the relationship $V_S = 0.333P$, where P is the pressure in pounds per square inch (psi). The circuit shown at the top of the next page is connected to the V_S output of the sensor. The LED (light-emitting diode) is supposed to turn on if the air pressure rises above about 15 psi. The LED should remain off for pressure levels below that level. The LED’s turn-on voltage V_F is 2.0 V and its maximum safe current is 25 mA. (A safety factor has already been applied, so 25 mA really is the LED’s maximum safe operating current.) Find the values of R_1 and R_2 that will cause the LED to turn on when the pressure reaches approximately 15 psi and that will allow the LED to stay just within (or slightly above) its safe current rating for all possible values of the sensor voltage V_S up to 10 V (corresponding to 30 psi). Specify the closest standard values for the resistors, assuming 5% tolerance. A table of standard resistor values is available on the Laboratory page at the course web site. Use the constant-voltage model for the LED.

(continued on next page)

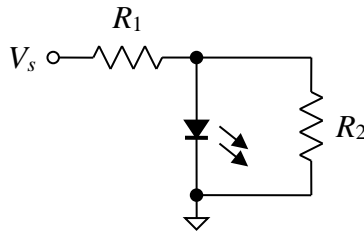

Circuit diagram for Ungraded Prob. 6

7. As shown below, a manufacturing error has resulted in diode D_2 being installed backwards in a standard full-wave rectifier circuit. The transformer's secondary voltage has a value of 6 V rms and is split evenly between the upper and lower windings (i.e., 3 V rms per winding). The voltages across the upper and lower windings are in phase. The turn-on voltage of each diode is 1.0 V. Sketch or describe the resulting output waveform $v_O(t)$. If necessary, include a plot of $v_{sec}(t)$ above the v_O plot to provide reference points. Label all important voltage values on the sketch. Also explain why the error would very likely lead to the failure of one or more components in the circuit.

